



Research article

Risk assessment of fire, explosion and release of toxic gas of Siri–Assalouyeh sour gas pipeline using fuzzy analytical hierarchy process

Mousa Jabbari ^a, Reza Gholamnia ^b, Reza Esmaeili ^c, Hasan Kouhpaee ^b, Gholamhossein Pourtaghi ^{d,*}^a Department of Occupational Health and Safety, School of Public Health and Safety, Shahid Beheshti University of Medical Sciences, Tehran, Iran^b Department of Health, Safety and Environment, School of Public Health and Safety, Shahid Beheshti University of Medical Sciences, Tehran, Iran^c Marine Medicine Research Center, Baqiyatallah University of Medical Sciences, Tehran, Iran^d Health Research Center, Lifestyle Institute, Baqiyatallah University of Medical Sciences, Tehran, Iran

ARTICLE INFO

Keywords:

Fuzzy risk assessment
Fuzzy analytical hierarchy process
Gas pipeline
Software

ABSTRACT

Background: Risk assessment of gas pipelines is very important because of various hazards and economic losses. Using fuzzy logic increases the reliability and accuracy of the results. The purpose of this study is to evaluate the fuzzy risk of fire, explosion and release of toxic gas in the pipeline using fuzzy analytical hierarchy process.**Methodology:** Extraction of all hazards from HAZOP and HAZID was carried out. Fuzzy risk assessment was performed using MATLAB software. Using fuzzy hierarchy process analysis, the weight of each basic risk item (BRI) was summed up in a framework, and the fuzzy risk level was determined with a five-state criterion including highly desirable, favorable, moderate, undesirable and highly undesirable.**Results:** The final risk score was equal to 0.1492, which according to the five-state criterion the risk level is in the favorable area. The highest risk score was related to hot work with open flame item with a risk score of 0.2485.**Conclusions:** The final risk score of fire, explosion and release of toxic gas in Siri–Assalouyeh gas pipeline is in the optimal area. Fuzzy risk assessment, compare to conventional risk matrices, provides more data to safety managers about the hazards and their rankings. Accordingly, the results are expected to be applicable to the safety managers while making decisions related to the risk management of gas pipelines.

1. Introduction

In the world, huge industrial events in case of pipelines have occurred, such as the natural gas pipeline explosion and fire on March 12, 2014, in Manhattan, New York, USA. It killed eight people, wounded 50, and displaced more than 100 families [1], bursting of a 30-inch natural gas pipeline on September 9, 2010 in San–Bruno, California, USA. 8 people were killed and many wounded and displaced, total destruction of 38 houses and damage to 70 other houses [2], gas leak from pipeline and then fire and explosion in LPG terminal of PEMIX in San–Juanico, Mexico City in 1984. 500 persons killed and whole of terminal were destroyed. Some of these events are already happening, endangering the lives of thousands of people and putting significant economic losses. Such disasters usually occur in several forms, but the usual consequence of them is fire, explosion and release of toxic gas.

Despite the fact that the use of gas transmission lines as transportation systems for liquids and hazardous gases is superior to other transport

methods in terms of cost, time and ease of transmission, but because of hazards such as explosion, flammability and Leakage will have harmful effects on humans and the environment, which, due to their linearity and the crossing of different areas and habitats, affect a vast range [3, 4, 5].

Process safety is one of the most important issues in industrial activities that should be measured through risk assessment methods. Although risk assessment is always associated with uncertainty and inaccuracy, fuzzy logic can solve the problem of uncertainty and inaccuracy in risk assessment and help to provide better insights on risk indicators and risk predictions [6]. Therefore, the risk assessment of gas pipelines is very important for various hazards and economic losses. So far, various studies have been undertaken to develop quantitative and qualitative methods for identifying and assessing the risk of pipelines, but using fuzzy logic in risk assessment has significant results. Fuzzy methods have ease of use and save time. Fuzzy models are reliable and provide accurate and detailed results that can be used in future studies [6].

* Corresponding author.

E-mail address: pourtaghi@bmsu.ac.ir (G. Pourtaghi).

Gharabagh et al. (2009) have conducted a study on the management and assessment of the comprehensive risk of transportation of petrochemical products and feedstocks, in which, using probabilistic and indexing models, an algorithm has been developed to assess the comprehensive risk assessment for pipeline management. In this study, the results of the relative risk assessment indicators as a regulator used to correct the pipeline failure rate were used [7]. Shahriyar et al (2011) used a fuzzy logic for risk analysis for oil and gas pipelines and used an fault tree analysis method to estimate the probability of failure and the method of event tree analysis to estimate the consequences of the failure event. And they used the bow-tie model to integrate them. This study also shows how interdependences in different factors may affect the results of the analysis. In order to carry out risk assessment for natural gas pipelines, use of the criterion of triple sustainability, including social, environmental and economic impacts [8]. Lavasani, Mohammad Reza et al. (2011) used the fuzzy theory to evaluate the risk of oil wells. In this study, basic risk items (BRIs) were estimated in a hierarchical framework based on a combination of probability and consequences. It used analytical hierarchy process (AHP) for weighting. Evidential reasoning was used for combining new information to update the estimated risks [9]. Lu, Linlin et al. (2015) presented a comprehensive risk assessment process for natural gas pipelines in a study combining risk matrix and bow-tie model. The fuzzy method was used to calculate the failure probabilities and for calculating severity, an indicator system was used that includes individual accidents, economic losses and environmental disturbances. Finally, a risk matrix including probability and consequence ranking criteria was proposed in order to arrive at the integrated results of the bow-tie model [10]. Bagheri et al. (2016) conducted a study to assess the risk of sour gas pipeline by combining CFD and Dose-Response models. In this study, individual risk is calculated in different modes and the safe distance from the pipeline is more than 100 m [11]. Guo et al. (2016) studied the gas pipeline risk assessment with the Petri Fuzzy Network (FPN) method. In this study, the parameters related to the objective and subjective factors were optimized and the weight of risk factors was derived from the combination of analytical Hierarchy process (AHP) and EM. The cloud model used to calculate the initial membership of risk factors for different risk ratings [12].

The purpose of present study is to identify hazards and determine the final level of risk of fire, explosion and release of toxic gas from pipeline and provide control strategies. Therefore, the following goals will be pursued:

- Extraction of all process and non-process hazards from HAZOP and HAZID studies,
- Assign a risk score for each of the basic risk items (BRIs) involved in the occurrence of fire, explosion and release of toxic gas from pipeline for fuzzy risk assessment (FRA),
- Weighing each of the basic risk items using the Fuzzy analytical Hierarchy Process (FAHP),
- Allocating final risk score of fire, explosion and release of toxic gas according to the five-state criteria, including highly desirable, favorable, moderate, undesirable and very undesirable.

The above objectives are used to determine the safety status of Siri-Assaluyeh sour gas pipeline and provide solutions to prevent fire, explosion and release of toxic gas in this pipeline. This pipeline is located in Pars Special Economic Energy Zone (ASALOUYEH).

2. Method

2.1. Study design

The present study is a cross-sectional descriptive study that was conducted in 2020 on Siri-Assaluyeh gas pipeline in Iran. This study was conducted in two main phases. In the first phase of the study, hazards were identified using HAZID and HAZOP techniques. Then, in the second

phase of the study, the fuzzy method was used to quantify and assessment of the risks of hazards identified in the first phase. Figure 1 illustrates the progress of the research process.

2.1.1. First phase: identifying hazards

In this step, effective risk factors of fire, explosion and release of toxic gas in the pipeline were obtained through HAZOP and HAZID studies, brain storming, library studies, and incidents occurring in studied pipelines.

2.1.1.1. HAZID technique. The Hazard Identification (HAZID) methodology is used to identify hazards as the first step in any risk assessment process [13]. In this technique, processes and tasks are broken down into components, and factors that lead to damage to workers, equipment, the environment, and reduced production are identified as hazards [14]. Also in this method, a team includes of experts working in the studied industry is formed and the risks are identified through brainstorming Which leads to the identification of major major accidents related to the process [15]. A HAZID worksheet starts with naming risk factors, followed by a possible accident caused by each risk factor. Then the potential causes and consequences are identified. Finally, correction recommendations or precautions may be provided [16].

2.1.1.2. HAZOP technique. The Hazard and operability (HAZOP) methodology was introduced in the 1960s as a "Critical Examination" technique for the chemical industry [17]. This technique is a process hazard analysis (PHA) method that is not only used to identify a system by examining the effects of any deviation from design conditions, but also used to study the operational problems of systems and processes [18]. This method can be implemented by a team of technicians and engineers (HAZOP team) with extensive knowledge in the field of design and maintenance of process industries. In a HAZOP study, process-related information including instruments diagrams and design documents such as piping and instrumentation diagrams, etc., is systematically reviewed by the HAZOP team, and the abnormal causes and adverse consequences of all deviations from normal performance in each part of the Processes are identified [19]. This technique uses a set of "guide words" to evaluate all possible process malfunctions and to investigate process deviations. Finally, all identified deviations and hazards are recorded in a checklist.

2.1.2. Second phase: risk quantification and risk assessment

In the second phase of the study, all identified risks related to the studied pipelines obtained from first phase are quantified using fuzzy methodology and the risk assessment process is performed.

2.1.2.1. Fuzzy risk assessment (FRA). The overall risk score will obtain through a traditional approach by multiplication of frequency and severity of the consequence as following equation [20]:

$$R = L \times S \quad (1)$$

"R" represents the risk score, "L" is the probability of an incident and "S" is the severity or outcome of the incident. Since probability and severity are expressed as fuzzy numbers, the risk score will also be a fuzzy number.

Figure 2 illustrates the main constructors of the hierarchical model structure for risk combining. Each of the components of risk is divided into its effective factors, which these factors themselves can divide into other factors with less impact. The overall risk is a unit that includes the main risk factors (parents) and the items affecting it (children), which in general are called risk families. The risk unit that does not have a child is called basic risk item. The method of marking risk items is X_{ij}^k , where "K" is a number that represents the current generation status of X, and "I" is a descriptive number of the child arrangement. "j" represents the order of the parents in X. Indicators "I", "j", and "k" are used to show the tendency of risk items. The factors L_{ij}^k (probability) and S_{ij}^k (severity) are defined as X_{ij}^k [21].

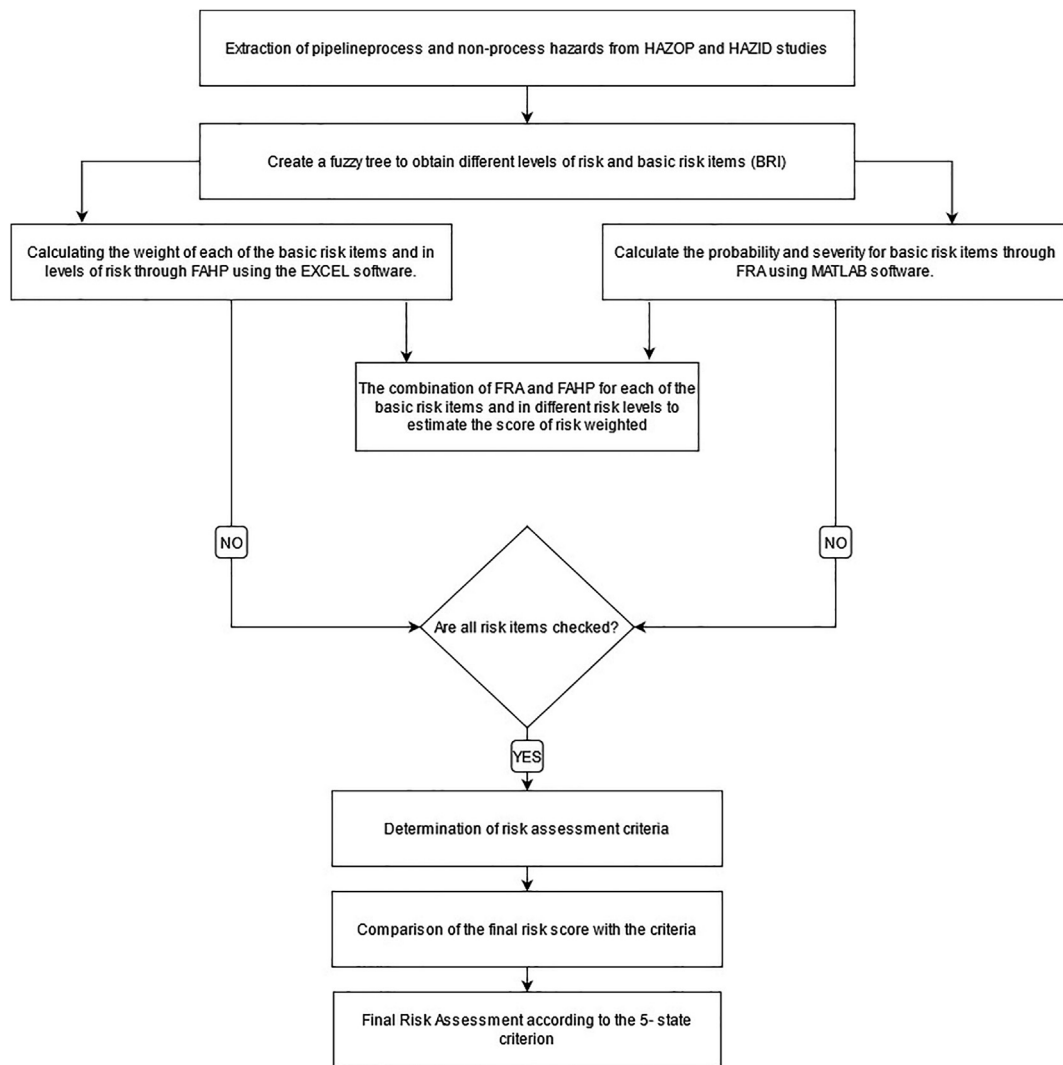

Figure 1. The progress of the research process.

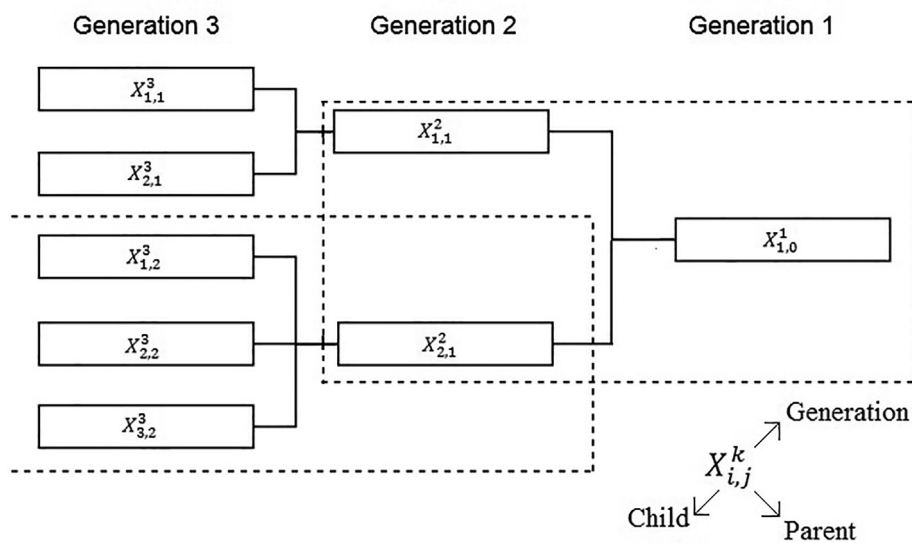

Figure 2. Hierarchical structure of risk items.

After verbally expressing the probability levels and severity by the experts for the basic risk items, these statements became fuzzy numbers so that the calculations can be done using mathematical relations and membership functions. In this study, Trapezoidal Fuzzy Number Likelihood (TPFNL) and Trapezoidal Fuzzy Number Severity were used to express the probability and severity [22]. Table 1 shows the linguistic definition of trapezoidal fuzzy numbers of probability and severity. Then the obtained fuzzy numbers corresponded to the global graph of fuzzy trapezoidal numbers and the fuzzy risk items were calculated [9].

2.1.2.2. Fuzzy analytical hierarchy process (FAHP). To obtain the weight of the basic risk items and their combination, triangular fuzzy numbers were used by using the fuzzy analytical hierarchy process in a risk hierarchy framework [23].

Table 2 illustrates the verbal definition of triangular fuzzy numbers for estimating the weight of risk items.

After estimating the fuzzy risks of the basic risk items and normalizing them, as well as obtaining the weight of the items at different risk levels, the final risk of fire, explosion and release of toxic gas in the pipeline was calculated by multiplying the fuzzy risks by the weight of each risk level and aggregating them in a framework through EXCEL software [9].

2.1.2.3. Determination of risk assessment criteria. To obtain a criteria for comparing final risk based on fuzzy multiplication $R = L * S$ and the relationship between hierarchical analysis and final scores, fuzzy risk assessment using hierarchical analysis has been performed for each of the different ranges as Table 3.

2.2. Statistical analysis

All calculations related to fuzzy risk assessment were performed using the MATLAB programming language. Finally, fuzzy weight and fuzzy hierarchy analysis were performed using EXCEL software.

3. Results

3.1. Risk identification phase results

All process hazards were extracted from HAZOP study as well as all non-process hazards through HAZID study. All process and non-process hazard can be seen in Table 4. In this table all items are marked with a symbol for ease of calculation in next phase. Two general perspectives were considered for identifying the elements that affect the fire, explosion and release of toxic gas of pipeline and assess the risks in the sour gas pipeline:

- (1) External fire resources,
- (2) Mixture of air and flammable vapors and release of toxic gas.

3.2. Results of fuzzy risk assessment phase

In this phase, risks were categorized to different levels according to their importance, risk sharing continued to the extent that each major risk was divided into the smallest risk constructors. These risks are called

basic risk items (BRIs). Figure 3 illustrates the hierarchical structure of fire, explosion and release of toxic gas in the studied pipeline.

Table 5 shows the basic risk items in the order of magnitude and their final risk level. For de-fuzzification items, it used the weighted average method with the following equation [24]:

$$RI = \sum_{i=1}^n Mi * \mu_i$$

In this equation, “RI” represents risk index, “ μ_i ” represents membership function of each basic risk item, “Mi” represents the qualitative weights of the set of fuzzy risk states, which are described for various situations: $M_{VL} = 0$, $M_L = 0.25$, $M_M = 0.5$, $M_H = 0.75$ and $M_{VH} = 1.0$.

The total results of the third, second and first level of risk were calculated, indicating the final risk score. Table 6 shows the final risk score of fire, explosion and release of toxic gas in the pipeline under study.

According to the calculations, the final risk score of fire, explosion and release of toxic gas in Siri-Assaluyeh gas pipeline was estimated at 0.1492.

The scores of risk assessment criteria for fire, explosion and release of toxic gas in Siri-Assaluyeh gas pipeline are as follows:

- For the very desirable status $X = 0.0308$,
- For the favorable status $X = 0.0913$,
- For the moderate status $X = 0.2795$,
- For the undesirable status $X = 0.5872$,
- For the very undesirable status $X = 0.7765$.

The final risk score for the pipeline will always be between 0.0308 and 0.7765. In order to determine the covering range of each state, the upper and lower limits must first be calculated. To do this, we must take the average from the score of two consecutive statuses.

Then, according to the scores obtained for the upper limit and the lower limit, the covering range of each status is defined. Hence, the upper and lower extremes of the highly desirable, favorable, moderate, undesirable and very undesirable slopes, as well as the location of the final risk of fire, explosion and release of toxic gas are shown in Figure 4.

4. Discussion

With the rapid advancement of technology and industrialization, the risk of accidents, such as fire, explosion and release of toxic chemicals, is increasing [25]. The storage and transport of flammable, explosive and toxic hydrocarbons cause disasters that are generally considered to be major hazards, the results of which are potentially subject to the two factors of the nature of hydrocarbon substances and their amount in the facility [26].

Process safety is one of the important components in the industry that should be measured by risk assessment methods. But risk assessment is accompanied by ambiguities and inaccuracy. Fuzzy logic is capable of solving uncertainty and inaccuracy in risk assessment and helps us to better understand risk indicators and process and non-process risk predictions [27].

In present study, the overall hazards of fire, explosion and release of toxic gas in the pipeline were extracted through HAZOP and HAZID

Table 1. Linguistic definition of trapezoidal fuzzy numbers of probability and severity [9].

Row	probability Qualitative scale (L)	Severity Qualitative Scale (S)	Trapezoidal fuzzy number (TPFN _L , TPFN _S)
1	Very low	Extremely unimportant	(0, 0, 0.1, 0.2)
2	low	unimportant	(0.1, 0.25, 0.4)
3	moderate	natural	(0.3, 0.5, 0.7)
4	high	important	(0.6, 0.75, 0.9)
5	Very high	Extremely important	(0.8, 0.9, 1, 1)

Table 2. Verbal definition of triangular fuzzy numbers for the weight of risk items [9].

Qualitative Descriptors of Severity	explanations	triangular fuzzy numbers
Equal importance	Two experts or attributes contribute equally to the event	(1,1,2)
Weak importance	Experience and judgment slightly favor an expert or attribute over another	(2,3,4)
Strong importance	Experience and judgment strongly favor an expert or attribute over another	(4,5,6)
Very strong importance	An expert or attribute is favored strongly over another	(6,7,8)
absolute importance	The evidence favoring expert or attribute over another is of the highest order of affirmation	(8,9,9)

Table 3. Classification of safety conditions for sour gas pipeline [9].

Interpreting the calculation	Pipeline status
R very low = L very low * S Extremely unimportant * FAHP	Very desirable
R low = L low * S unimportant * FAHP	favorable
R moderate = L moderate * S neutral * FAHP	moderate
R high = L high * S important * FAHP	undesirable
R very high = L Extremely high * S Extremely * FAHP	Very undesirable

Table 4. Display of basic risk items with a symbol according to HAZOP and HAZID methods.

Symbol	explain	Symbol	Explain
X ¹ _{1,0}	Fire, explosion and release of toxic gas in the pipeline	X ⁴ _{1,3}	Hot work with open flame
X ² _{1,1}	External resources of fire	X ⁴ _{2,3}	Negligence (cigarette, Matches etc)
X ² _{2,1}	Mixture of air and vapors in the flammable range and release of toxic gas	X ⁴ _{1,1}	MOV1044–1045 failure and launcher opening
X ³ _{1,1}	Additional fire resources	X ⁴ _{2,1}	Closing GOV 1050/1005 and increasing pressure above design pressure of pipeline down stream
X ³ _{2,1}	Electric sparks	X ⁴ _{3,1}	Abrupt opening of the receiver door
X ³ _{3,1}	Open flame	X ⁴ _{4,1}	PV001/002 failure and upstream pressure rise
X ³ _{1,2}	Operational errors	X ⁴ _{5,1}	Suddenly unlocking MOV1046 without balancing
X ³ _{2,2}	gas leakage	X ⁴ _{6,1}	Toxic gas release from PSV on GOV
X ³ _{3,2}	Increased pipeline back pressure	X ⁴ _{1,2}	Corrosion
X ⁴ _{1,1}	The fire of pipelines and nearby facilities	X ⁴ _{2,2}	GASKET failure
X ⁴ _{2,1}	War and sabotage	X ⁴ _{3,2}	TPD (third party damage)
X ⁴ _{3,1}	Flame return from Flare	X ⁴ _{4,2}	Marine anchor collision with sea lines
X ⁴ _{1,2}	Electric induction of power lines	X ⁴ _{5,2}	Natural disasters (earthquakes, tsunamis, etc.)
X ⁴ _{2,2}	Lightning collision	X ⁴ _{1,3}	FV001/006 failure
X ⁴ _{3,2}	Static sparks	X ⁴ _{2,3}	The closure of any manual valve

studies. After the fuzzy tree was constructed, the basic risk items (BRIs) were evaluated using fuzzy risk assessment (FRA) and fuzzy analytical hierarchy process (FAHP), and the final score of the risk of fire, explosion and release of toxic gas in the pipeline was equal to 0.1492, indicating the pipeline safety status in the optimal area. In present study, fuzzy logic was used to evaluate risk, which gives more accurate results, while previous studies such as Gharabagh et al. [7] and Bagheri et al. [11] have used the classic risk assessment method.

Using MATLAB software for data analysis, in addition to increasing the computational speed, has also increased the accuracy of the results and is one of the major differences between previous studies, including Lavasani et al. [9]. Using fuzzy logic in risk assessment of pipelines is one of the similarities of this research with previous studies like Raeihagh et al [28], Lu et al. [10] and Guo et al. [12]. In Yazdi study, an intuitionistic fuzzy-hybrid-modified TOPSIS approach was used to assess the risks in a gas refinery for welding tasks. According to the results using fuzzy approach increase in the accuracy of the risk assessment process compared to conventional methods [29]. The results were in consistent with the present study.

In the present study, the risks of "Hot work with open flame", "The fire of pipelines and nearby facilities", "Closing GOV 1050/1005 and increasing pressure above design" had the highest risk levels with a risk index of 0.4310, 0.3087 and 0.2032, respectively. Also, the risks of

"Natural disasters (earthquakes, tsunamis...)", "Negligence (cigarette, Matches, etc)" and "Suddenly unlocking MOV1046 without balancing" had the lowest risk with a risk index of 0.0041, 0.0055, and 0.0064, respectively. According to the results, process factors had the greatest effect on the change in risk level. In the study by Ahmed and Gu [30], which was conducted to prioritize boiler risks in a marine boiler, process risks also had the greatest impact on the level of risk. Besides that, in the study of Fang et al. [31], Which was performed to assess the quantitative risk on natural gas pipelines, process variables such as excessive material pipelines, industrial activities, welding defects and improper maintenance had a high impact on pipeline leakage. the results of both were consistent with the present study.

In the Wang and Duan study, which was conducted to the comprehensive risk assessment of oil and gas pipelines, the results showed that external interference was the major cause of accidents. According to the results of the present study, external interference such as third party damage, Marine anchor collision with sea lines and Closing GOV 1050/1005 and increasing pressure above design pressure of pipeline down-stream had a great impact on the final risk index [32]. Other previous studies also confirm the high effect of third-party activities on pipeline final risk level [33, 34].

In this study, the risk of "War and sabotage" had very little effect on the final risk level of the process. While in the study of Zhang et al., The

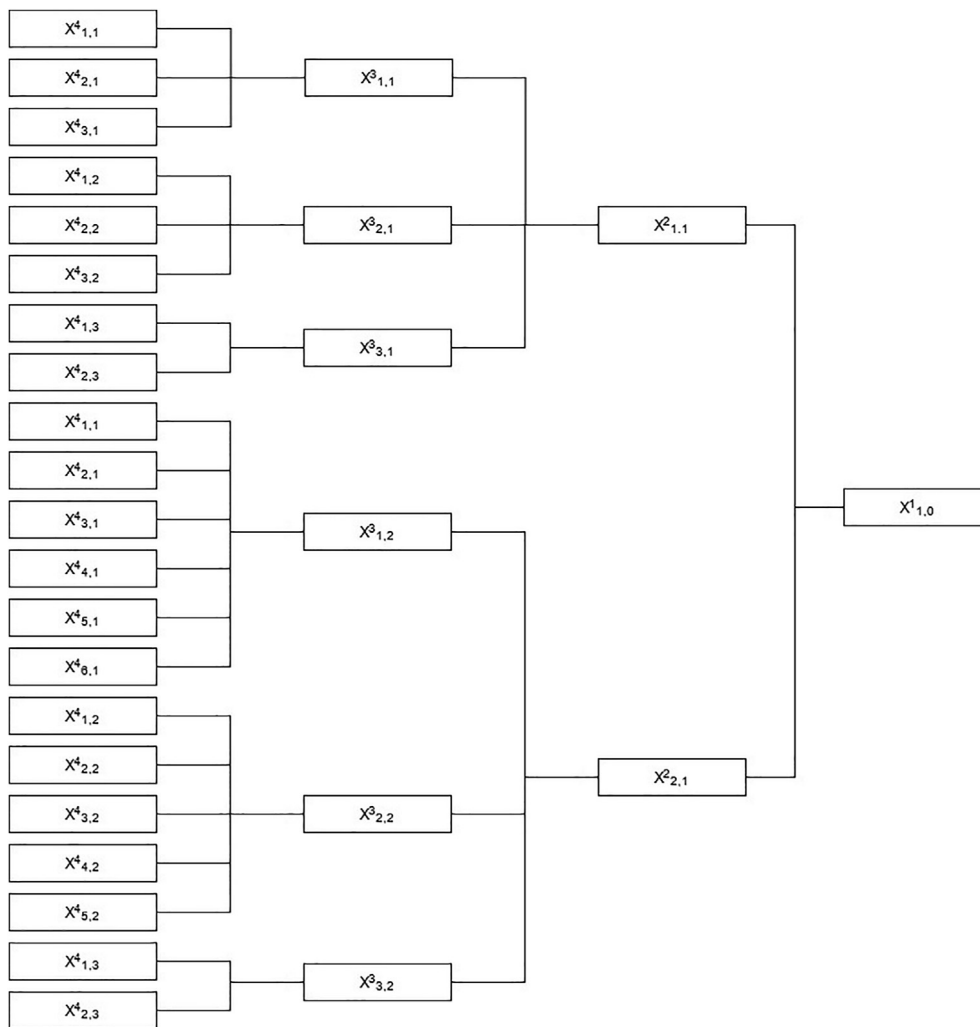

Figure 3. Hierarchical structure of fire, explosion and release of toxic gas of Siri-Assaluyeh pipeline.

Table 5. Prioritizing basic risk items based on risk rating and fuzzy weight.

symbol	Basic risk item	VL	L	M	H	VH	Risk Index	Risk status
$X^4_{1,3}$	Hot work with open flame	0.0000	0.2221	0.5288	0.1481	0.0000	0.4310	Moderate
$X^4_{1,1}$	The fire of pipelines and nearby facilities	0.0000	0.1785	0.3642	0.1093	0.0000	0.3087	Moderate
$X^4_{2,1}$	Closing GOV 1050/1005 and increasing pressure above design pressure of pipeline down stream	0.0171	0.2117	0.2697	0.0205	0.0000	0.2032	Moderate
$X^4_{3,2}$	TPD	0.0950	0.1979	0.0851	0.0000	0.0000	0.0920	Favorable
$X^4_{4,2}$	Marine anchor collision with sea lines	0.0925	0.1927	0.0828	0.0000	0.0000	0.0896	Favorable
$X^4_{1,2}$	Electric induction of power lines	0.0067	0.0828	0.1055	0.0080	0.0000	0.0795	Favorable
$X^4_{1,3}$	FV001/006 failure	0.3305	0.2275	0.0000	0.0000	0.0000	0.0569	Very desirable
$X^4_{2,2}$	GASKET failure	0.0041	0.0506	0.0644	0.0049	0.0000	0.0485	Very desirable
$X^4_{1,2}$	Corrosion	0.0000	0.0225	0.0535	0.0150	0.0000	0.0436	Very desirable
$X^4_{2,2}$	Lightning collision	0.5403	0.1567	0.0000	0.0000	0.0000	0.0392	Very desirable
$X^4_{1,1}$	MOV1044–1045 failure and launcher opening	0.0438	0.0796	0.0247	0.0000	0.0000	0.0323	Very desirable
$X^4_{3,1}$	Abrupt opening of the receiver door	0.0593	0.0803	0.0173	0.0000	0.0000	0.0287	Very desirable
$X^4_{2,3}$	The closure of any manual valve	0.3653	0.0767	0.0000	0.0000	0.0000	0.0192	Very desirable
$X^4_{3,2}$	Static sparks	0.0378	0.0512	0.0110	0.0000	0.0000	0.0183	Very desirable
$X^4_{2,1}$	War and sabotage	0.1204	0.0506	0.0000	0.0000	0.0000	0.0127	Very desirable
$X^4_{3,1}$	Flame return from Flare	0.1372	0.0398	0.0000	0.0000	0.0000	0.0100	Very desirable
$X^4_{4,1}$	PV001/002 failure and upstream pressure rise	0.0497	0.0343	0.0000	0.0000	0.0000	0.0086	Very desirable
$X^4_{6,1}$	Toxic gas release from PSV on GOV	0.0070	0.0147	0.0063	0.0000	0.0000	0.0068	Very desirable
$X^4_{5,1}$	Suddenly unlocking MOV1046 without balancing	0.0373	0.0257	0.0000	0.0000	0.0000	0.0064	Very desirable
$X^4_{2,3}$	Negligence (cigarette, Matches etc)	0.0789	0.0221	0.0000	0.0000	0.0000	0.0055	Very desirable
$X^4_{5,2}$	Natural disasters (earthquakes, tsunami...)	0.0237	0.0163	0.0000	0.0000	0.0000	0.0041	Very desirable

Table 6. Final risk of fire, explosion and release of toxic gas in Siri-Asalouye pipeline.

$X^2_{i,j}$	VL	L	M	H	VH	F	VL	L	M	H	VH
$X^2_{1,1}$	0.14978	0.20908	0.10563	0.0935	0	$X^1_{1,0}$	0.2618	0.4047	0.2016	0.1018	0.0000
$X^2_{2,1}$	0.11204	0.19566	0.09602	0.00826	0						
						LG (P)	0.0140	0.0770	0.2760	0.5770	0.8580
							0.0037	0.0312	0.0557	0.0587	0.0000
						X	0.1492				



Figure 4. Comparison of final risk status with risk criteria.

effect of third-party sabotage on the risk level of pipelines was high, which seems to be the reason for this difference in the level of security of the two study environments [35]. Also In the study of Kraidi et al. [36] In contrast to the present study, terrorism and sabotage had a significant effect on the final risk index of pipelines. Therefore, it can be said that the security level of countries also affects the risk index of processes such as pipelines.

In the study of Fang et al. [31], Which was conducted with the aim of quantitative risk assessment of natural gas pipelines using bow-tie technique and the use of Bayesian networks, the results showed that the probability of third party intervention was 0.0425. In the present study, the identified risk of "War and sabotage" was 0.0127. The results of these two studies were almost similar and consistent.

As mentioned above, in our study, the risks of natural disasters had the least effect on the final risk index. And also in the study of Kraidi et al., natural disasters had a low effect on the final risk Index of pipelines [36].

In the Badida et al. study [37] which was aimed to evaluate the risk of oil and natural gas pipelines du to natural hazard implementing fuzzy fault tree analysis, the fuzzy failure probability related to land environment natural hazard such as earthquake was 3.866E-09 while as previously mentioned, the risk score related to natural disasters in this study was 0.0041. This difference between two studies maybe is due to the differences between study locations.

Also in the present study, corrosion of pipelines had a low risk index level compared to the total risk index level; this indicates the use of up-to-date facilities in the present study, While in the study of Kraidi et al. [36] The corrosion status of pipelines had a high risk index. Therefore, the results of both studies show the high effect of pipeline status on the final risk level. In addition to In the Badida et al. study [37] the risk score of corrosion due to various factors was between 2.501E-08 and 5.329E-06 which was lower than risk of corrosion in present study. This difference seems to be due to the different locations between the two studies.

Finally, as shown in Figure 4, the final risk level of the pipeline was "Favorable", which indicates the proper state of the process. Therefore, continuous monitoring and risk assessment of pipelines can be effective to keep going in this situation. It is also recommended that process hazards are constantly monitored and, if possible, appropriate control measures such as their confinement is taken to ultimately reduce the level of risk posed by them.

The results of present work have obtained through an application of fuzzy risk assessment to determine the risk score related to fire, explosion and release of toxic gas of Siri-Assalouyeh Sour Gas pipeline. Due to the

lack of historical information in the studied pipeline and the existing uncertainty to estimate and calculate the risk score using existed risk assessment methods such as risk matrices, the use of fuzzy risk assessment to calculate the risk of identified hazards leads to increase study accuracy and decrease uncertainty in the calculation of risks.

For future studies, researchers are recommended to:

- (a) Conduct a fuzzy and classic risk assessment simultaneously and compare the results
- (b) In completing this project, a consequence modeling is recommended for the accurate assessment of the effects of the consequences of fire, explosion and release of toxic substances,
- (c) GIS software is recommended to better integrate the consequences and plan control measures in different pipeline sections.

5. Conclusion

In the present study, in the first phase, hazards related to fire, explosion and release of toxic gas in the studied pipelines were identified using HAZID and HAZOP methods. These techniques make it possible to identify hazards and their causes in any industrial processes. Then, in the second phase, the risk assessment process was performed using fuzzy linguistic and also defuzzification of the identified hazards in the first phase. The use of fuzzy linguistic has a much higher accuracy compared to conventional risk matrices in situations where the risk assessment process is accompanied by uncertainty. Finally, according to the results of the first and second phases, the identified risks were classified into five categories as follow: very undesirable, Undesirable, Moderate, Favorable and very desirable. Accordingly, the risks identified in this study were in three following categories: Moderate, Favorable and very desirable. As indicated in Figure 4, the final risk score of fire, explosion and release of toxic gas in Siri-Assaluyeh gas pipeline is in the optimal area. The highest risk score for basic items is related to hot work with open flame with the risk index of 0.431 and also the lowest risk score was related to Natural disasters (such as earthquakes, tsunami...) with the risk index of 0.0041. Fuzzy risk assessment, compare to conventional risk matrices, provides more data to safety managers about the hazards and their rankings, thus it helps manager offering more effective safety management strategies which are narrowing the number of critical hazards. Accordingly, in order to improve the safety status of the studied pipeline, the following corrective and control measures are proposed:

- Enhancing the work permit system (PTW)
- Allocating the gas and fire (F&G) detection system
- Training maneuvering for operational personnel
- Operational teams' standby when performing repairs
- Preparing an emergency response plan (ERP)

Declarations

Author contribution statement

Mousa Jabbari: Conceived and designed the experiments.
 Reza Gholamnia: Analyzed and interpreted the data.
 Reza Esmaeili: Analyzed and interpreted the data; Wrote the paper.
 Hasan Kouhpaee: Performed the experiments; Wrote the paper.

Gholamhossein Pourtaghi: Conceived and designed the experiments; Contributed reagents, materials, analysis tools or data.

Funding statement

This work was supported by Shahid Beheshti University of Medical Sciences (Grant Number: 14069).

Data availability statement

The data that has been used is confidential.

Declaration of interests statement

The authors declare no conflict of interest.

Additional information

No additional information is available for this paper.

Acknowledgements

Thanks are given to the Pars Special Economic Energy zone Organization and Pars Oil and Gas Company for cooperation in this research.

References

- [1] K. Wang, T. Shi, Y. He, M. Li, X. Qian, Case analysis and CFD numerical study on gas explosion and damage processing caused by aging urban subsurface pipeline failures, *Eng. Fail. Anal.* 97 (2019) 201–219.
- [2] C. Scawthorn, S. Li, R.A. Davidson, J. Kelly, L.C. Long, D.A. McEntire, et al., San Bruno California, September 9, 2010 Gas Pipeline Explosion and Fire, Disaster Research Center, 2012.
- [3] M. Mirzaei Aliabadi, R. Esmaeili, I. Mohammadfam, M. Ashrafi, Human reliability analysis (HRA) using standardized plant analysis risk-human (SPAR-H) and Bayesian network (BN) for pipeline inspection gauges (PIG) operation: a case study in a gas transmission plant, *Health Scope* 8 (3) (2019 Aug 31).
- [4] W.K. Muhlbauer, *Pipeline Risk Management Manual: Ideas, Techniques, and Resources*, Elsevier, 2004.
- [5] M. Mirzaei Aliabadi, R. Esmaeili, I. Mohammadfam, M. Ashrafi, Application of a standardized plant analysis risk-human reliability method to pipeline inspection gauge operations, *J. Occup. Hyg. Eng.* 6 (3) (2019) 34–43.
- [6] K.B. Mishra, K.-D. Wehrstedt, H. Krebs, Lessons learned from recent fuel storage fires, *Fuel Process. Technol.* 107 (2013) 166–172.
- [7] M.J. Gharabagh, H. Asilian, S. Mortasavi, A.Z. Mogaddam, E. Hajizadeh, A. Khavanin, Comprehensive risk assessment and management of petrochemical feed and product transportation pipelines, *J. Loss Prev. Process. Ind.* 22 (4) (2009) 533–539.
- [8] A. Shahriar, R. Sadiq, S. Tesfamariam, Risk analysis for oil & gas pipelines: a sustainability assessment approach using fuzzy based bow-tie analysis, *J. Loss Prev. Process. Ind.* 25 (3) (2012) 505–523.
- [9] S.M. Lavasani, Z. Yang, J. Finlay, J. Wang, Fuzzy risk assessment of oil and gas offshore wells, *Process Saf. Environ. Protect.* 89 (5) (2011) 277–294.
- [10] L. Lu, W. Liang, L. Zhang, H. Zhang, Z. Lu, J. Shan, A comprehensive risk evaluation method for natural gas pipelines by combining a risk matrix with a bow-tie model, *J. Nat. Gas Sci. Eng.* 25 (2015) 124–133.
- [11] M. Bagheri, A. Alamdari, M. Davoudi, Quantitative risk assessment of sour gas transmission pipelines using CFD, *J. Nat. Gas Sci. Eng.* 31 (2016) 108–118.
- [12] Y. Guo, X. Meng, D. Wang, T. Meng, S. Liu, R. He, Comprehensive risk evaluation of long-distance oil and gas transportation pipelines using a fuzzy Petri net model, *J. Nat. Gas Sci. Eng.* 33 (2016) 18–29.
- [13] K. Kim, H. Kang, Y. Kim, Risk assessment for natural gas hydrate carriers: a hazard identification (HAZID) study, *Energies* 8 (4) (2015) 3142–3164.
- [14] D. Siddiqui, A. Nandan, M. Sharma, A. Srivastava, Risk management techniques HAZOP and HAZID study, *Int. J. Occup. Health Saf. Fire Environ. Allied Sci.* 1 (1) (2014) 5–8.
- [15] J. Nakayama, J. Sakamoto, N. Kasai, T. Shitubani, A. Miyake, Preliminary hazard identification for qualitative risk assessment on a hybrid gasoline-hydrogen fueling station with an on-site hydrogen production system using organic chemical hydride, *Int. J. Hydrogen Energy* 41 (18) (2016) 7518–7525.
- [16] M. Leimeister, A. Kolios, A review of reliability-based methods for risk analysis and their application in the offshore wind industry, *Renew. Sustain. Energy Rev.* 91 (2018) 1065–1076.
- [17] H. Lawley, Operability studies and hazard analysis, *Chem. Eng. Prog.* 70 (4) (1974) 45–56.
- [18] J. Dunjov, V. Fthenakis, J.A. Vílchez, J. Arnaldos, Hazard and operability (HAZOP) analysis. A literature review, *J. Hazard Mater.* 173 (1-3) (2010) 19–32.
- [19] J.L. Fuentes-Bargues, C. González-Gaya, M.C. González-Cruz, V. Cabrelles-Ramírez, Risk assessment of a compound feed process based on HAZOP analysis and linguistic terms, *J. Loss Prev. Process. Ind.* 44 (2016) 44–52.
- [20] A.S. Markowski, M.S. Mannan, Fuzzy risk matrix, *J. Hazard Mater.* 159 (1) (2008) 152–157.
- [21] H. Deng, Multicriteria analysis with fuzzy pairwise comparison, *Int. J. Approx. Reason.* 21 (3) (1999) 215–231.
- [22] W. Karwowski, A. Mital, Potential applications of fuzzy sets in industrial safety engineering, *Fuzzy Set Syst.* 19 (2) (1986) 105–120.
- [23] C.-H. Cheng, Evaluating naval tactical missile systems by fuzzy AHP based on the grade value of membership function, *Eur. J. Oper. Res.* 96 (2) (1997) 343–350.
- [24] R. Sadiq, Y. Kleiner, B. Rajani, Aggregative risk analysis for water quality failure in distribution networks, *J. Water Supply Res. Technol. - Aqua* 53 (4) (2004) 241–261.
- [25] Z. He, W. Weng, A dynamic and simulation-based method for quantitative risk assessment of the domino accident in chemical industry, *Process Saf. Environ. Protect.* 144 (2020) 79–92.
- [26] R. Shen, Z. Jiao, T. Parker, Y. Sun, Q. Wang, Recent application of Computational Fluid Dynamics (CFD) in process safety and loss prevention: a review, *J. Loss Prev. Process. Ind.* (2020) 104252.
- [27] M.T. Amin, F. Khan, P. Amyotte, A bibliometric review of process safety and risk analysis, *Process Saf. Environ. Protect.* 126 (2019) 366–381.
- [28] H. Raeihagh, A. Behbahani, M.M. Alegha, Risk assessment of sour gas inter-phase onshore pipeline using ANN and fuzzy inference system—Case study: the south pars gas field, *J. Loss Prev. Process. Ind.* 68 (2020) 104238.
- [29] M. Yazdi, Risk assessment based on novel intuitionistic fuzzy-hybrid-modified TOPSIS approach, *Saf. Sci.* 110 (2018) 438–448.
- [30] S. Ahmed, X.-C. Gu, Accident-based FMECA study of Marine boiler for risk prioritization using Fuzzy expert system, *Results Eng.* (2020) 100123.
- [31] W. Fang, J. Wu, Y. Bai, L. Zhang, G. Reniers, Quantitative risk assessment of a natural gas pipeline in an underground utility tunnel, *Process Saf. Prog.* 38 (4) (2019), e12051.
- [32] X. Wang, Q. Duan, Improved AHP-TOPSIS model for the comprehensive risk evaluation of oil and gas pipelines, *Petrol. Sci.* 16 (6) (2019) 1479–1492.
- [33] A. Liu, K. Chen, X. Huang, D. Li, X. Zhang, Dynamic risk assessment model of buried gas pipelines based on system dynamics, *Reliab. Eng. Syst. Saf.* (2020) 107326.
- [34] K. Shan, J. Shuai, K. Xu, W. Zheng, Failure probability assessment of gas transmission pipelines based on historical failure-related data and modification factors, *J. Nat. Gas Sci. Eng.* 52 (2018) 356–366.
- [35] Y. Zhang, S. Lv, W. Wang, Risk analysis of high pressure gas pipeline leakage based on bow-tie model and IAHP, *EES (Ecotoxicol. Environ. Saf.)* 461 (1) (2020), 012079.
- [36] L. Kraidi, R. Shah, W. Matipa, F. Borthwick, Using stakeholders' judgement and fuzzy logic theory to analyze the risk influencing factors in oil and gas pipeline projects: case study in Iraq, Stage II, *Int. J. Crit. Infrastruct. Protect.* 28 (2020) 100337.
- [37] P. Badida, Y. Balasubramaniam, J. Jayaprakash, Risk evaluation of oil and natural gas pipelines due to natural hazards using fuzzy fault tree analysis, *J. Nat. Gas Sci. Eng.* 66 (2019) 284–292.